

Crystal characterization and crystal filter design

An overview of tools and techniques

Nick Kennedy, WA5BDU

Joplin, MO April 26, 2008

Goals of this presentation

- Describe some methods of crystal characterization (e.g. measurement of parameters), the hardware required, and the measurement techniques used
- Discuss and describe some available filter design software (generally free) and its use, including software to analyze proposed designs before building
- Define some common terms and discuss tips and precautions for filter design and the merits of various popular designs
- Convince the typical ham builder that crystal filter design is neither too expensive nor too complex for him to attempt

From impossible to easy – some history

- 1960s – No PC design software. No PCs either! And no handheld calculators. Prevailing crystal filter design is a lattice or half lattice using custom ordered crystals on different frequencies, too expensive for the typical ham. Also, no signal generators with 1 Hz readout and enough stability for measuring crystal parameters.
- 1976+ RGSB's Technical Topics reports on F6BQP's experiments with ladder filters utilizing crystals all on the same frequency. Crystal parameters aren't measured, but guidelines for capacitor sizes produce workable filters. J.A. Hardcastle G3JIR is doing similar work with ladder filters published in the UK as well as QST in 1978 and 1980. Surplus color TV crystals are inexpensive.
- 1980+ Wes Hayward W7ZOI publishes several influential articles, authors crystal filter design software as a commercial venture and later included packaged with two of his books. Hayward also developed measurement schemes and promoted G3UUR's method.
- Disclaimer: This slide isn't meant to accurately state "who did what first" – it's just an over view.

Model of a crystal

- Series parameters L_m and C_m are most important. R_s is needed to determine Q and does affect filter design to an extent
- C_0 is the holder capacitance. Responsible for so-called “LSB shape” of the ladder filter. Measure with an ordinary capacitance meter or estimate
- L_m and C_m can be calculated by measuring BW (Q) and R_s , or by inserting a series capacitance and measuring the series resonant frequency shift.
- Series resonance is the peak at left on the plot

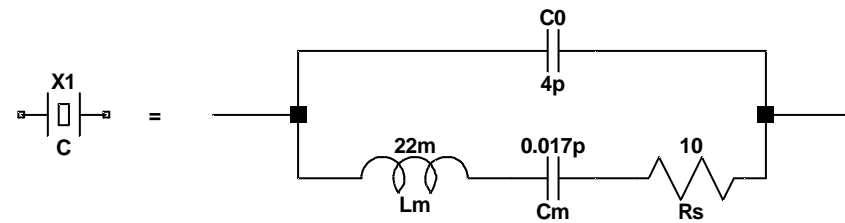

Equivalent circuit of a crystal
 L_m = motional inductance
 C_m = motional capacitance
 R_s = equivalent loss resistance
 C_0 = holder capacitance

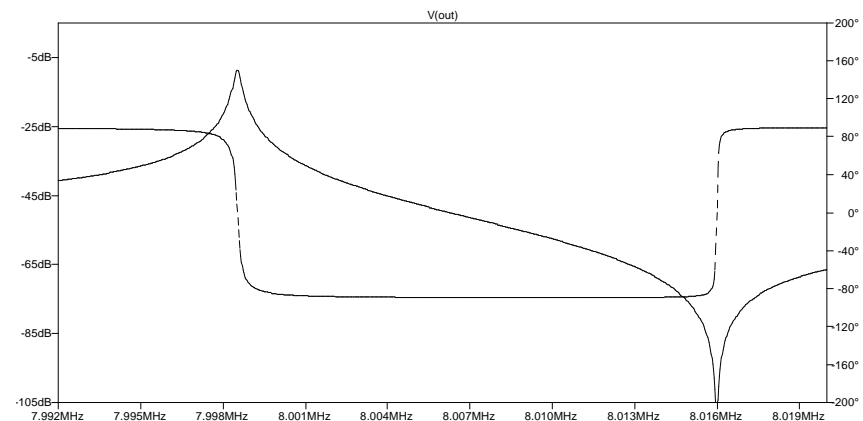

BW / Q method of parameter measurement

- Two means of expressing Q of a tuned circuit are $Q = F/BW$ and $Q = X/R$
- We know F (nameplate frequency of the crystal). If we measure BW (3 dB bandwidth) and R, we can solve for X, which is the reactance of Lm or Cm (they are equal). Then Lm and Cm follow easily.
- The crystal needs to “see” a well defined resistance on each end, typically 50 ohms or 12.5 ohms. The total circuit R will be twice this value plus Rs.
- The bandwidth (BW) will be small, maybe 200 Hz or so, we need an accurate frequency reading and a stable generator
- We don't need a fancy meter to show -3dB points. Just a relative reading of voltage and a simple 3 dB pad that can be switched in and out.
- The Q we measure is loaded Q. Crystal Q is X/R_s

Signal Generator

- For BW / Q method, 1 Hz readout and stability needed
- Some examples in my shack include:
 - NJQRP DDS synthesizer
 - Multi-Pig PLL/VCO oscillator plus counter
 - K8IQY PVXO precision VXO plus counter
- Generator should have a defined (typ 50 ohm) source R
- This can be achieved by adding 50 ohm in/out pads to the output
- The generator should put out a good, low distortion sine wave. Uses low pass filtering as needed.

Detector for BW / Q method

- After the crystal test fixture (and possibly some amplification) comes the detector, which is just a (typically) 50 ohm load and an RF voltmeter
- The voltmeter can be a simple 1N34A diode detector and DMM as in the K8IQY and W1FB circuits, or an amplified (“NORTEX Accu-Probe”) and compensated RF probe if your circuit has high attenuation or low drive amplitude
- Some homebrewers may prefer to use their oscilloscope to view the amplitude of the signal at the 50 ohm load
- If the -3 dB switchable pad is used, only a relative reading is needed. Otherwise, reading a peak value and then 0.707 times that value is required.
- I use a Kanga log power meter as my detector

One WA5BDU test set-up

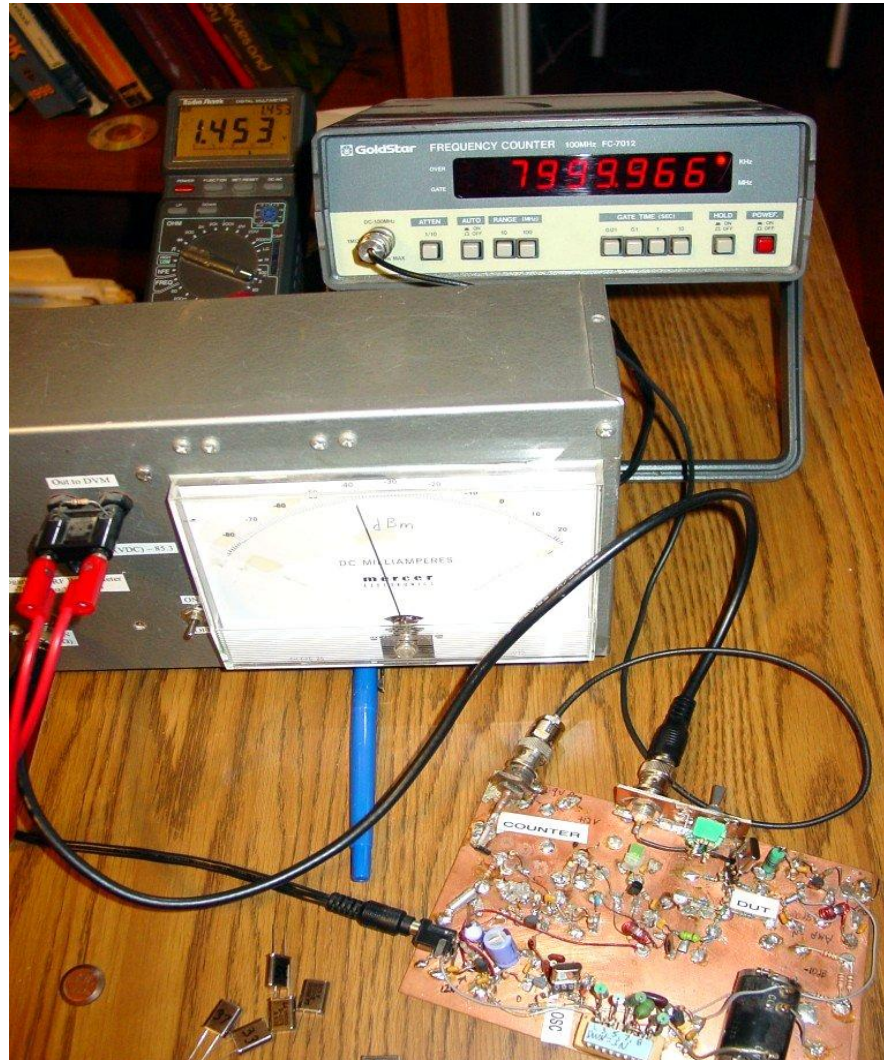

Typical set-up for BW & Rs

- The schematic on the next slide is from K8IQY
- The signal generator connects at the upper left
- Note that 3 dB 50 ohm pads are used before and after the 4:1 transformers to further well establish a defined resistance in both directions.
- The 4:1 transformers put the crystal in a 12.5 ohm “environment”. This is the industry standard value, but 50 ohms is sometimes used.
- Following the crystal is an amplifier to boost the signal to a level suitable for a simple diode detector, which is selected in the lower position of the DPDT switch
- Not shown is a switchable -3 dB attenuator

Sample test setup for BW & Rs

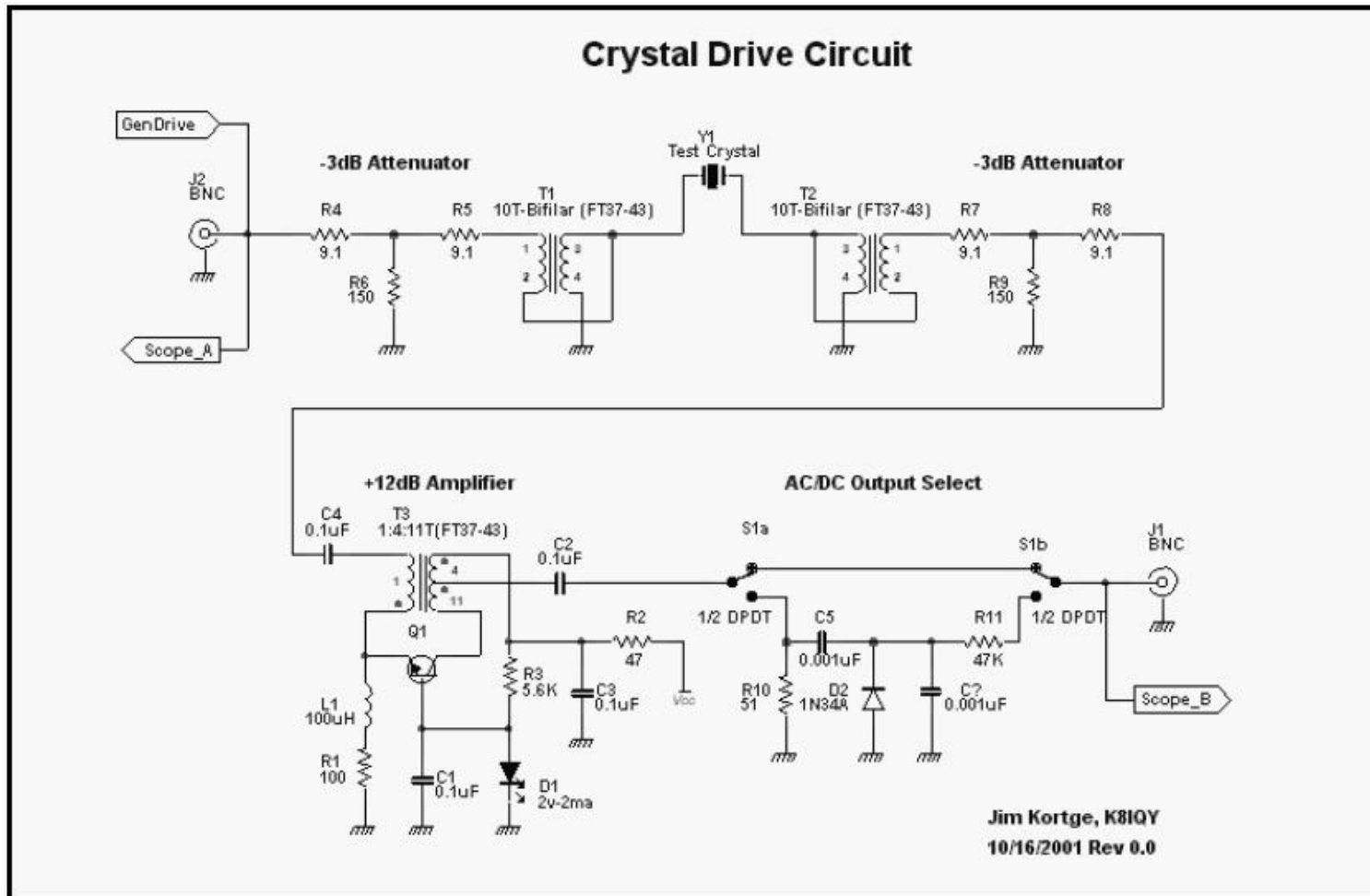

Test circuit with resistive pads

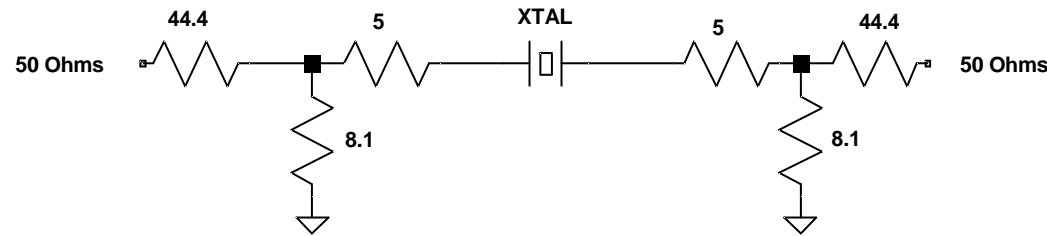

Crystal test fixture using 50 to 12.5 ohm minimum loss pads
Loss in each pad is 16 dB.
8.1 ohm resistors are 2-16.2 ohm R in parallel
5 ohm resistors are 2-10 ohm R in parallel
Resistance looking in is ~50 ohms
Crystal sees 12.5 ohms looking out

- Alternate method for crystal in a 12.5 ohm environment
- 32 dB loss requires more signal or sensitive detector (Keeping the output load at 12.5 ohms for load/detector would reduce the loss by 16 dB)
- This circuit corrects an error in my AmQRP #3 article which omitted the 5 ohm resistors toward crystal
- BW is that of crystal with 12.5 source and load resistance, despite actual 50 ohms utilized(!)

-3 dB switchable pad & BW method

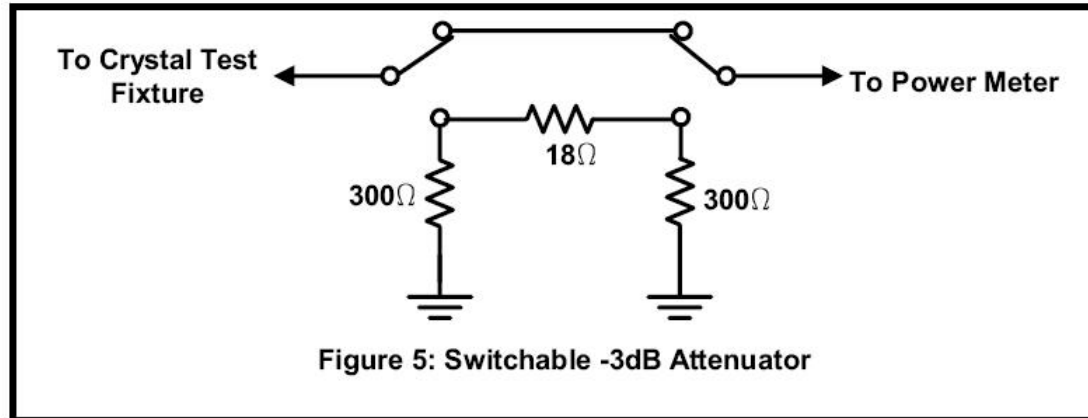

- Pad is in the 50 ohm signal path, before or after crystal
- Pad IN, vary F to find peak reading and F_c (center)
- Pad OUT, decrease F until same meter reading, F-low
- Increase F above F_c to same reading for F-hi
- BW = F-hi – F-low
- Q (loaded) = F_c / BW [continued next slide]

BW & Q method continued

- Note meter reading at F_c with crystal installed
- Remove crystal and insert 25 ohm pot
- Adjust pot for same reading as with crystal
- Remove pot and measure. Reading is R_s
- $C_m = BW / (2 * \pi * F_c^2 * (2 * R_g + R_s))$, where R_g is the resistance of the generator or detector, 12.5 ohms here
- $L_m = 1 / (39.48 * F_c^2 * C_m)$ (39.48 is $4 * \pi^2$)
- Now you know all the motional parameters. Measure C_o with a capacitance meter and go design your filter
- You can estimate C_o as $C_o = 220 * C_m$
- This completes the BW & Q method

Alternate method for Rs

$$R_s = 2R_g \left(10^{\frac{\alpha}{20}} - 1 \right)$$

If you are equipped to measure the difference in output (dBm) with crystal installed and at resonance versus with a jumper in place of the crystal, you can find Rs this way.

Rg is the source (and/or load) resistance. Alpha is the attenuation from the crystal in dB, meaning the difference in the two measurements expressed in dB.

Note that with the G3UUR method, you must take an educated guess at Rs or Q. Maybe 120,000 or so. By one analysis, changing a known filter's Q to 75% of that value did not have a major effect on shape or slope

Shifted frequency G3UUR method

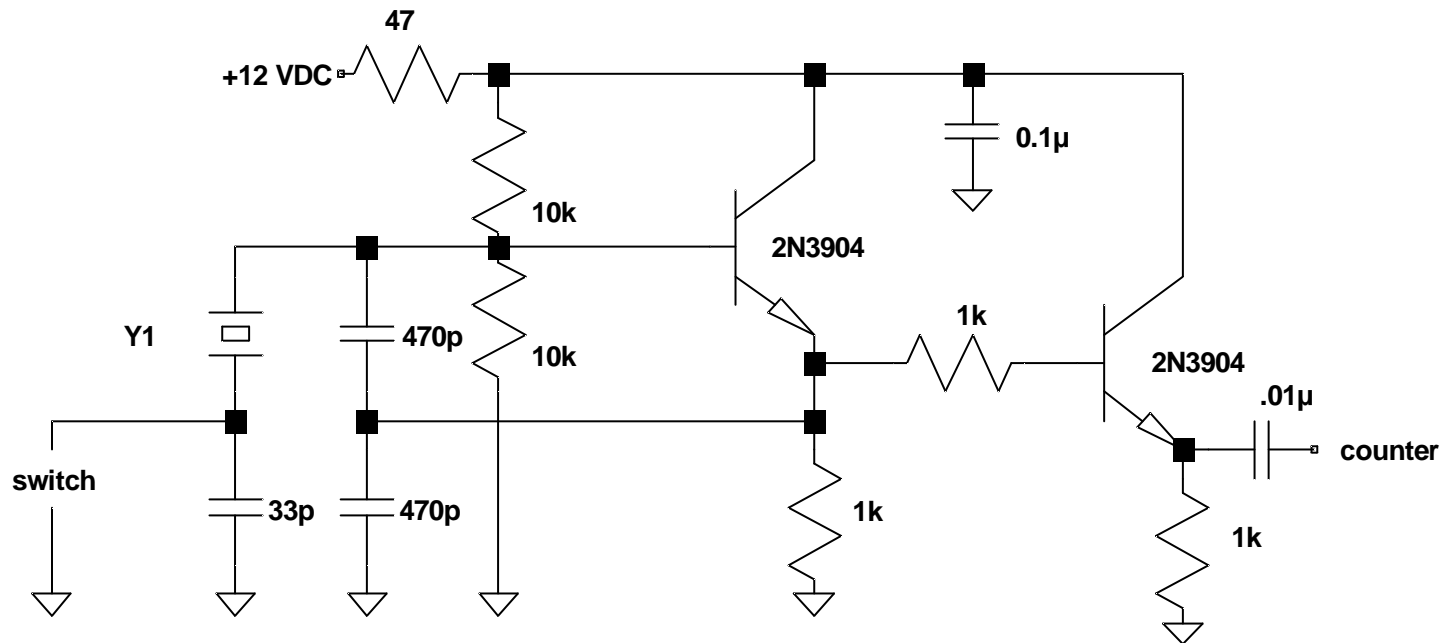

Oscillator used for G3UUR crystal parameter measurement method
Frequencies recorded with switch open and closed are used to calculate
 L_m and C_m

G3UUR measurement method

- Measure the frequency with the switch open (f_1)
- Measure the frequency with the switch closed (f_2)
- Plug into the formulas for L_m and C_m and you're done
- This method does not measure R_s
- Measure C_o with a capacitance meter or estimate as in the BW / Q method
- **Chris Trask N7ZWY circuit for frequency shift**
- Improved oscillator assures series resonance operation
- Also incorporates measurements to give R_s
- Relatively new with few user comments as yet

<http://www.home.earthlink.net/~christrask/Crystal%20Test%20Set.pdf>

G3UUR formulas

Basic formulas:

$$C_m = 2(C_s + C_o) \frac{\Delta f}{f} \quad L_m = \frac{1}{(2\pi f)^2 C_m}$$

Where C_s is the capacitor switched in and out of the circuit and C_o is the holder capacitance. Delta- f is the difference in the two measured frequencies and f is the nominal frequency of the crystal.

On the next page are the formulas I derived to account for the Colpitts network capacitors

G3UUR – more refined equations

$$C_m = \frac{(f_1^2 - f_2^2)(C_1 C_2)}{f_2^2 C_2 - f_1^2 C_1} \quad \text{where}$$

$$C_1 = \left(\frac{1}{C_{c1}} + \frac{1}{C_{c2}} + \frac{1}{C_s} \right)^{-1} + C_o \quad \text{and}$$

$$C_2 = \left(\frac{1}{C_{c1}} + \frac{1}{C_{c2}} \right)^{-1} + C_o$$

Cc1 and Cc2 are the Colpitts divider capacitors. Cs is the switched series capacitance. Lm is calculated from Cm the same way as in the basic G3UUR formulas.

How accurate are the readings?

- Darell Brehm WA3OPY measured my crystals on ICM's professional equipment and passed them to Bill Carver K7AAZ to measure on a N2PK VNA
- I compared them to my own measurements using the BW/Q method, G3UUR method with original and enhanced calculations, and Chris Trask method
- Measurements generally agree to within 5% or better
- When I changed the Lm/Cm values on an XLAD filter design by 5%, the resulting shape still looked very good although the BW changed a bit.

Round-robin crystal tests

Lm by measurement

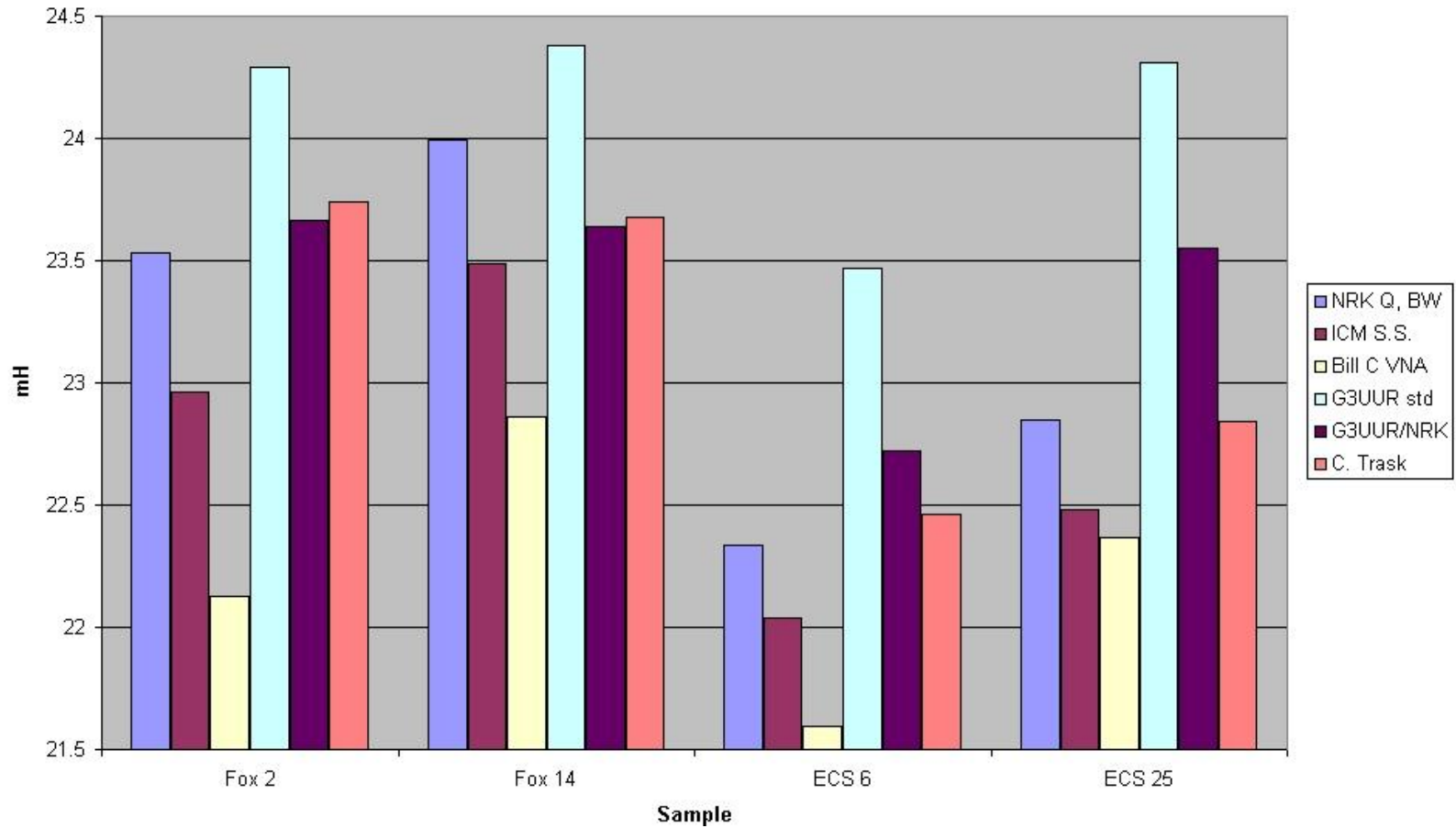

Tests normalized to ICM & Carver

Lm normalized to S.S. + VNA

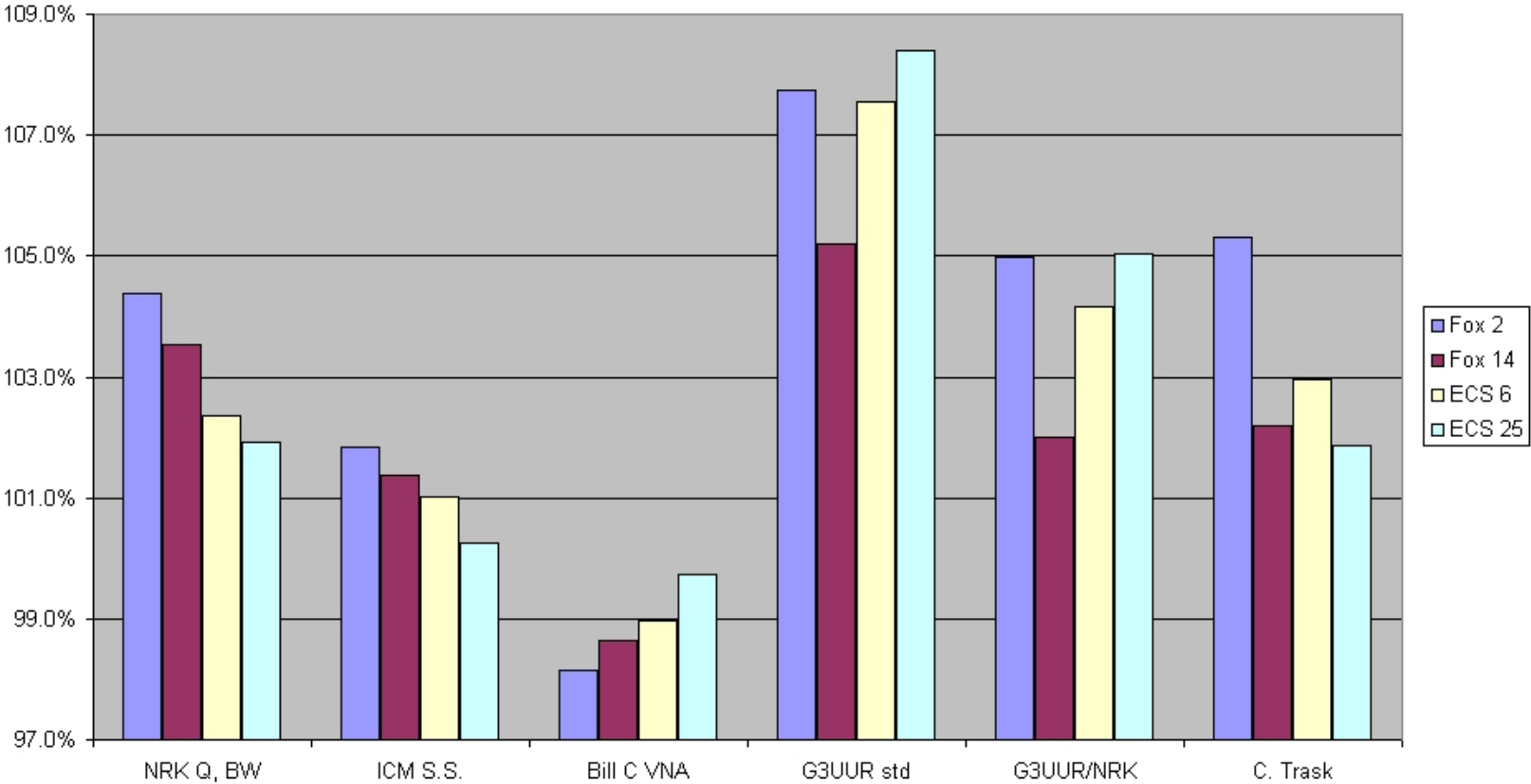

The assumed actual value for each crystal is the average of the ICM & Carver measurements

Designing your filters

- Crystal filter design is a rather complex process if done from the base mathematics or using coefficients from a book. Moreover, books with tables adjusted for non-optimum Q (“predistorted”) are specialized and somewhat expensive at \$70 and up used.
- Software to the rescue ...
- Wes Hayward’s XLAD and GPLA programs were originally sold commercially, then included in DOS versions with IRFD, then Windows versions in EMRFD.
- AADE’s Filter Design program was originally commercial but became freeware recently.
- Both perform design and provide analysis (response curves).

XLAD & GPLA

- XLAD designs the filter. It asks for frequency, L_m , Q and C_o of the crystals and desired filter bandwidth.
- Minimum end resistances aren't given directly, but can be found by reducing until an error occurs. Higher values are matched with end capacitors.
- Designs a Gaussian to 6 dB, Butterworth, or Chebyshev
- Provides tuning capacitors for the meshes
- File saved by XLAD can be analyzed (response curves) by GPLA. The LadBuild program will show the circuit schematically if the subscripted data is confusing
- XLAD attempts to compensate for Q and C_o . If BW as seen on GPLA is off, adjust and run XLAD again.

XLAD.EXE

xtal_ladder_filter_design

File About XLAD

XLAD Follow instructions in numeric order:

F, MHz Motional L, Henry Q-u C0, pF

1. Enter or edit crystal parameters and click **1. Characterize Crystal**

Filter Bandwidth, Hz. Number of Crystals in Filter:
 B = N =

2. Enter/Edit B and N and click **2. Basic Filter**

2A.(Optional) For Chebyshev or Butterworth designs, click: **2A. Chebyshev**

q1 qn

3. Enter or Edit End Normalized Q values and click **3. End Q Parameters**

End Resistance 4. Enter or Edit End R and click: **4. Match Ends**

k1-2 k2-3 k3-4 k4-5 k5-6

k6-7 k7-8 k8-9 k9-10

5. Enter or Edit the Normalized coupling coefficients and click: **5. Calculate Coupling Caps**

Shunt Coupling Capacitors, pF

C12=	<input type="text" value="61.31"/>	C67=	<input type="text" value="81.84"/>
C23=	<input type="text" value="81.84"/>	C78=	<input type="text" value="61.31"/>
C34=	<input type="text" value="86.45"/>	C89=	<input type="text" value="0.00"/>
C45=	<input type="text" value="87.47"/>	C9-10=	<input type="text" value="0.00"/>
C56=	<input type="text" value="86.45"/>		

6. Edit Coupling and End Caps, if desired, and Tune Filter:

6. Tune the Filter Series Tuning Capacitors, pF

CT1=	<input type="text" value="1679.50"/>	CT6=	<input type="text" value="210.83"/>
CT2=	<input type="text" value="99999.00"/>	CT7=	<input type="text" value="99999.00"/>
CT3=	<input type="text" value="210.83"/>	CT8=	<input type="text" value="1679.50"/>
CT4=	<input type="text" value="180.84"/>	CT9=	<input type="text" value="0.00"/>
CT5=	<input type="text" value="180.84"/>	CT10=	<input type="text" value="0.00"/>

Shunt End Capacitors
 C-1, pF C-N, pF

A Tuning Cap. of 99999 indicates a wire when building the filter.

GPLA analysis program

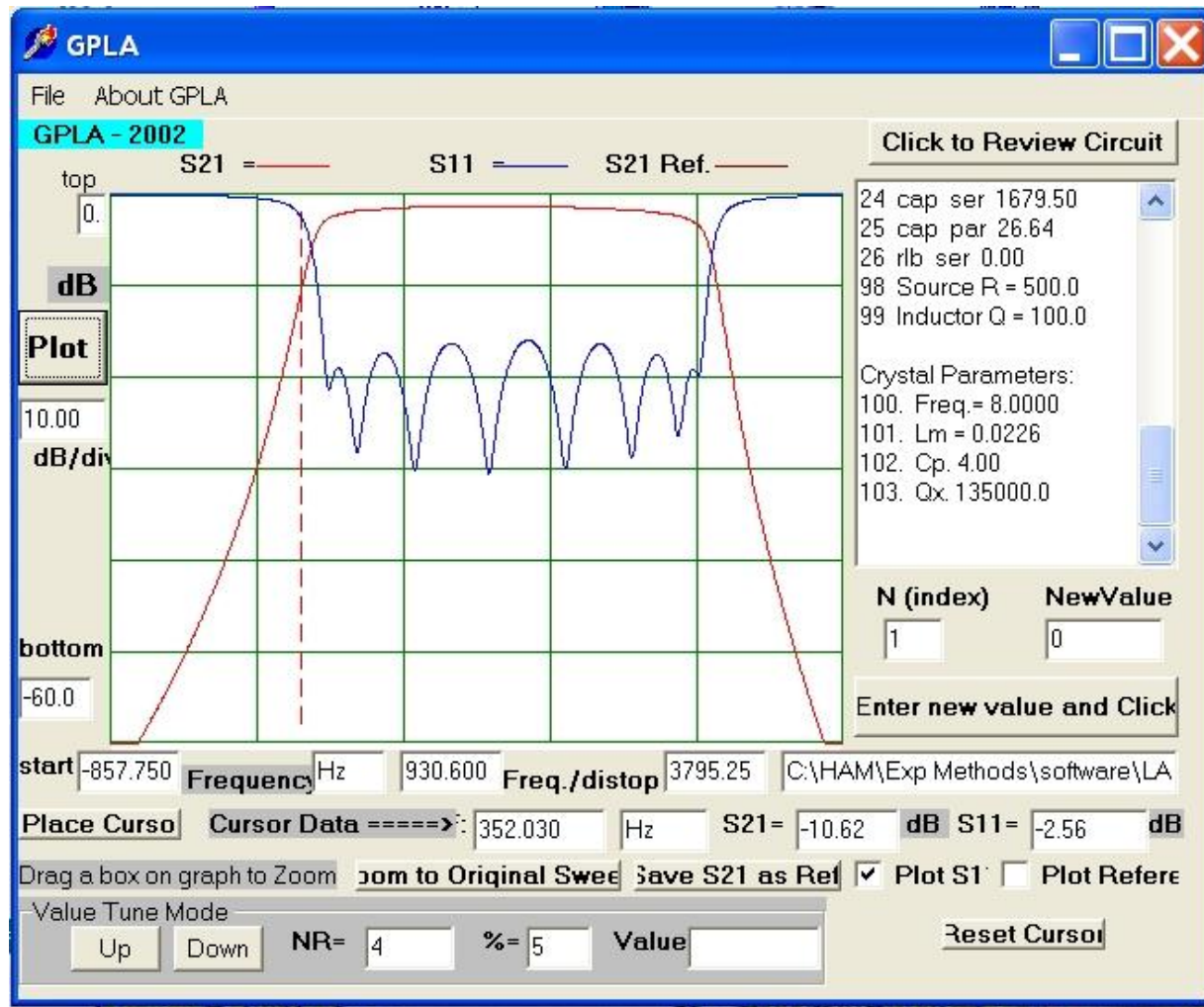

Meshes and mesh tuning

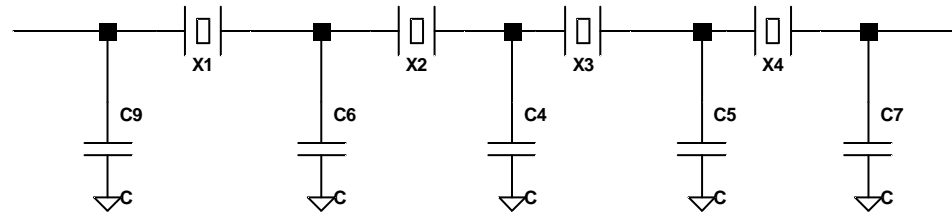

- Here's a typical crystal ladder filter
- Each crystal in series with the capacitors on left and right to ground form a mesh having a certain resonant frequency
- Proper performance requires each mesh to have the same resonant frequency. All but the highest frequency mesh(es) may have to be brought up with series capacitors.
- Differences in crystal frequencies may be exploited to provide proper mesh frequencies

Filter with tuned meshes

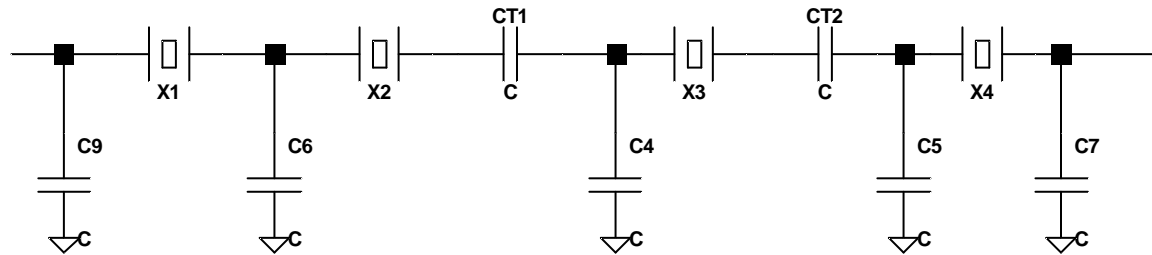

- Here the inside meshes are tuned to match the outside ones with capacitors CT1 and CT2.
- XLAD and AADE provide tuning capacitor values.
- Some builders actually measure individual mesh resonant frequencies and tune them.
- End resistive loading makes tuning of the end meshes less critical than inner meshes due to broadening of the peak.

AADE Filter Design

The screenshot displays the AADE Filter Design V4.2.1 software interface. The main window title is "AADE Filter Design V4.2.1" and the menu bar includes "FILE", "UTILITIES", "ANALYZE", "DESIGN", "OPTIONS", "WINDOW", and "HELP".

The "Crystal Parameter Choices" dialog box is open, showing a circuit diagram of a crystal model with components R_s , C_s , L_s , and C_p . A green box on the right of the dialog box contains the text: "Click on which set of parameters is known from measurements taken in a test setup similar to that shown." Below this are several radio button options for different parameter sets: "Fs, Ls, Cs, and Q Known", "Fs, Ls, Cs, and Rs Known", "Fs, Fp, and Rs Known", "Fs, Fp, and bw Known", and "Fs, Rs, and Q Known".

The "Enter data" dialog box is also open, featuring a calculator pad on the left and input fields for C_p , L_s , C_s , and Q_x . The values entered are $C_p = 3.5p$, $L_s = 22.718m$, $C_s = .01744p$, and $Q_x = 125.016318K$. A red box at the bottom of the "Enter data" dialog box contains the text: "Enter the crystals parallel capacitance in Farads. L/C Meter II will measure it." The calculator pad includes buttons for digits 0-9, mathematical operators (+, -, *, /, %, =), and unit prefixes (M, K, m, μ , n, p).

AADE analysis screen

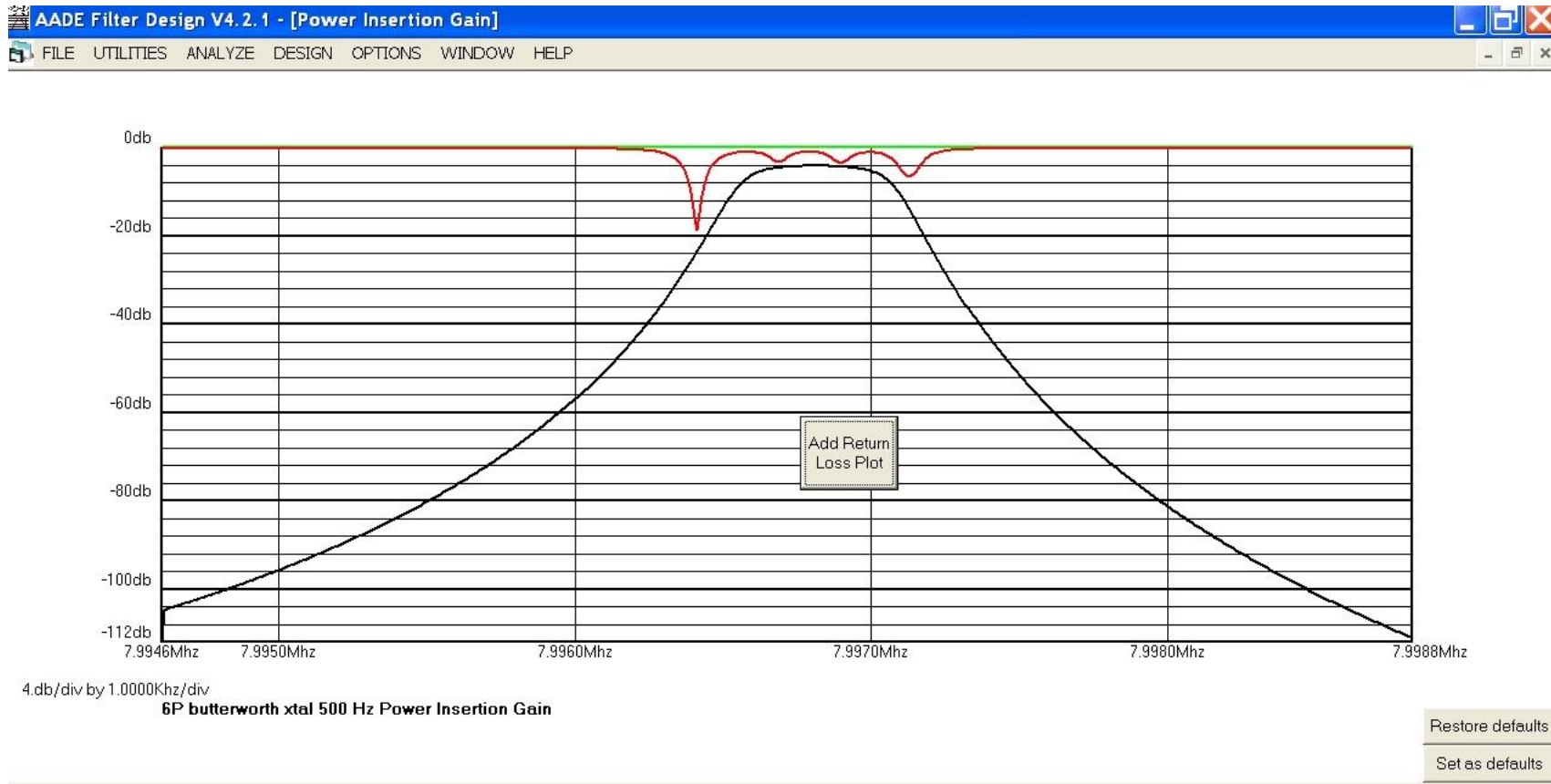

AADE Filter Design

- User input is similar to XLAD. User inputs L_m , C_m , Q or R_s , C_o and desired bandwidth. (AADE symbols vary for these parameters)
- Filter Design offers about a dozen common and less common crystal filter types, Butterworth, Chebyshev, Gaussian, Bessel, Linear Phase, Cohn, etc.
- AADE designs a matching L/C end section to match higher or lower loads compared with XLAD's shunt capacitors to match higher R values
- Results with AADE or XLAD designer will typically be high or low on bandwidth on the first attempt, as viewed on the analyzer software. Adjust and repeat as required.

Other analysis software: SPICE

- There's little need for additional software since both XLAD and Filter Design include software to display the response curves.
- But other software, such as LTSpice allow options such as using specific parameters for each crystal instead of average values for the set. Also, the user may want to view filter performance with pre- and post- filter amplifiers, for example.
- Regardless of the analysis tool, response curves allow calculating a figure of merit known as shape factor, which is the ratio of bandwidth at -6 dB and -60 dB points

Matching - both directions

- The filter requires termination in the design resistance value on both ends to perform properly
- The view looking into the filter from the driver or load stage normally presents the same resistance value
- The return loss plot will tell how well the filter does this. Higher return loss means a better match.
- If necessary, a resistive pad or intermediate amplifier with well defined input and output R might be needed, for example between the mixer and the crystal filter
- Generally, your filter's design resistance is constrained by various factors to a certain range. You'll match it to required values in your design with transformers, networks, etc.

Co - can we make it more complicated?

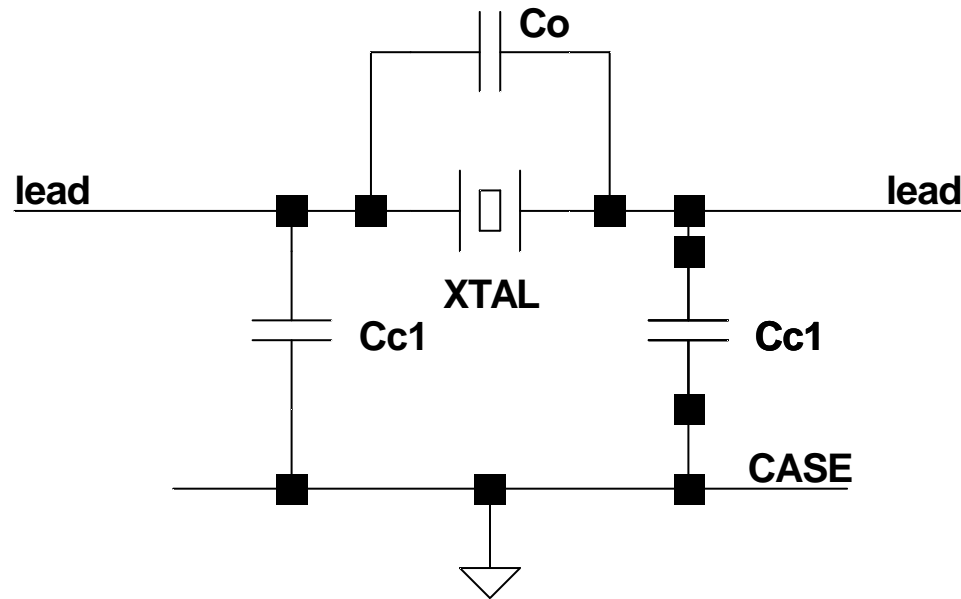

Yes! C_o is the capacitance of the electrode plates and crystal. But there's also a C from each plate to the case. When you measure lead-to-lead, you measure C_o plus $C_{c1}/2$. To find C_{c1} , connect the leads together and measure to the case. That gives $2 * C_{c1}$.

Co adjustments continued

- If you ground your crystal cases, reduce the measured C_o by $1/2$ of the C_{c1} measurement
- If in your filter you have a coupling capacitor C_{jk} between crystals j and k to ground, you should reduce its design value by $C_{c1} * 2$ when you ground your crystal cases
- These corrections are generally used by more exacting builders and may usually be omitted without serious problems. Designs with small capacitor values may benefit more from the adjustments.

What kind(s) of crystals & capacitors?

- Dipped silver mica capacitors are often used but other quality RF capacitors may be used
- Keep an assortment of values. Combining in parallel or series will usually allow hitting calculated values within a pF or two. Measuring each capacitor rather than trusting the marking is a good idea.
- HC49/U crystals are often used by amateurs in filters. Perhaps contrary to intuition, the shorter HC49/US crystals can also have good Q.
- As a case in point, consider the space limited ATS-3 with short crystals and SMT ceramics but good performance.

That LSB shape

- Crystal ladder filters typically have a response curve that is less steep on the lower side due to the effect of Co. Less pronounced with larger number of poles.
- This is generally not a problem but may be with very wide filters
- One method of compensation described by Hayward is to add resonating inductors in parallel with each crystal. This technique produces a symmetrical shape around the passband, but be aware that well removed from the filter frequency, ultimate rejection is reduced somewhat
- The Dishal filter design can produce a USB shape. The AADE program describes and implements it

What type of filter?

- Since they generally look alike physically and schematically, difficulty of building is not a consideration
- We trade steep sides and flatness of passband against time domain behavior and “sound”
- Our response curves show attenuation of sine waves over a range of frequencies. They do not show phase shifts and delays at each discrete frequency. These may affect naturalness of sound, “ringing” behavior, and distortion of timed pulses used in data modes
- Mathematical descriptions of the derivation of various filter shapes are interesting but complex. The homebrewer will generally research qualitative descriptions and choose the type for his application

Filter types - continued

- Chebyshev 0.1 dB is perhaps the most common choice for SSB & CW filters
- Chebyshev and Butterworth filters will both have some ringing and delay affecting digital modes. Types more optimal for digital modes include Gaussian, Gaussian to 6 and 12 dB, and linear phase types
- The Cohn or “min-loss” filter is a favorite among experimenters because the capacitors are all of equal value. As such, mesh tuning capacitors are not needed. Note that the end capacitors in the Cohn filter are series (not shunt).

Assessing filter performance

- Generally, actual performance is reasonably close to predicted so measurements aren't absolutely necessary
- Your qualitative assessment -- install the filter in your receiver and listen -- can be the most valuable test
- I record response at discrete points using my log power meter and signal generator, then plot the result in Excel
- Obviously, a spectrum analyzer will give the best and easiest to produce picture of filter performance
- One effective but inexpensive method is to use PC soundcard software such as Spectrogram. Use a noise generator into your receiver and pipe the audio to the PC. It won't go to -100 dB, but shows the overall shape well

Facts, opinions & quotes

- C_o (holder capacitance) is usually approximated by $C_o = 220C_m$, which is derived from the physics of an AT cut crystal. Add $\frac{1}{2}$ to 1 pf to this (rule of thumb) (1) (2)
- Always ground the crystal case. (3) (Note that some authors state that they do not ground the case for fear of damage caused by soldering.)
- If the crystal case is grounded, reduce the measured C_o by half the capacitance measured from both pins shorted together to the case. (3)
- Chebyshev filters tear up the timed pulses of RTTY, AMTOR, or Clover signals. Two good choices for data modes are Gaussian-6-dB and Gaussian-to-12 dB designs.

- Filter bandwidth has been found to be inversely proportional to the square root of the coupling capacitance. (6)
- Wider filters operate at higher impedances and have smaller coupling capacitors. (7)
- Miniature, wire-ended crystals (e.g., HC49/U) require a higher circuit impedance than HC-6/U types. (6)
- A Chebyshev with 0.1 dB of ripple is the most commonly used response type for SSB HF filters. (9)
- The recommended frequency range for an SSB crystal filter is between 6 and 12 MHz. (9)
- There is no physical difference between a “parallel” and a “series” type crystal.
- Choose crystals with a maximum frequency spread of about 10% of your filter bandwidth

- The difference between the series and parallel resonant frequency of a crystal can be approximated fairly closely with this formula:

$$\Delta f \cong \frac{f \times C_m}{2C_o}$$

- From the AADE Help text (quoting Hayward), the normalized Q of the filter must be greater than twice the number of crystals in the filter, or

$$2 * \# \text{ of crystals} < Q_u * BW / f \text{ where}$$

Q_u is the unloaded Q of the crystals, BW is the filter bandwidth, and f is the crystal frequency

References

1. Refinements in Crystal ladder Filter Design, Wes Hayward, W7ZOI QEX June 1995
2. An Oscillator Scheme for Quartz Crystal Characterization, Wes Hayward, from his web page
3. Why Crystal Filters? Bill Carver, W7AAZ notes for FDIM presentation
4. Designing and Building Simple Crystal Filters, Wes Hayward, W7ZOI QST 7/87 *
5. A Tester for Crystal F, Q and R, Doug DeMaw, W1FB, QST 1/90 *
6. Ladder Crystal Filter Design, J.A. Hardcastle, G3JIR QST11/80 *
7. High-Performance Crystal Filter Design, Bill Carver, Communications Quarterly, Winter 93 *
8. Some Experiments with High-Frequency Ladder Crystal Filters, J.A. Hardcastle, G3JIR QST 12/78
9. Designing and Building High-Performance Crystal Ladder Filters, Jacob Makhinson, N6NWP QEX 1/95

10. Crystal Motional Parameters – A Comparison of Measurement Approaches, Jack Smith, K8ZOA 6/06 from the web - www.cliftonlaboratories.com/Documents/Crystal%20Motional%20Parameters.pdf
11. A Practical Test Set for Comprehensive Crystal Testing, Chris Trask, N7ZWY from his web site
12. Designing the Z90's Gaussian Crystal Filter, Jack Smith, K8ZOA, QEX May/Jun 2007
13. Simplified Tools and Methods for Measuring Crystals, Jim Kortge, K8IQY, AmQRP Homebrewer #7, Spring 2006, (also issue #6, Summer 2005)
14. Build a 'Precision Variable Crystal Oscillator' , Jim Kortge, K8IQY, AmQRP Homebrewer #6, Summer 2005
15. Quartz Crystal Resonators and Oscillators, John R. Vlg, U.S. Army Communications-Electronics Command, AD-A3228861
16. "Filter Design" program Help text, AADE (Neil Hecht)

Sources for documents

- The CD from EMRFD contains several classic articles on crystal measurements and filter design
- The AADE “Filter Design” program’s Help section also includes several classic papers
- ARRL’s “QRP Power” book includes two papers on crystal measurement and filter design
- The ARRL web site includes a number of relevant papers from QEX and QST for its members